

## **ADDENDUM NUMBER 1**

**Project Title:** Mackey Complex Renovation and Addition-  
PID 10383 – Hardscape, Bid Package 06-01D – 2010

**ISSUE DATE: April 26, 2010**

Bidders are hereby notified that the Bidding and Contract Documents for the above project, for which Bids are to be received on **Thursday, May 13, 2010**, are amended as follows:

### General

1. THE CONSTRUCTION DOCUMENTS INCLUDE BOTH THE PROJECT MANUAL AND THE DRAWINGS. SEE VOLUME I OF THE PROJECT MANUAL FOR BIDDING REQUIREMENTS, CONTRACT FORMS, GENERAL CONDITIONS, AND PROJECT INFORMATION INCLUDING THE SPECIFIC SCOPE DESCRIPTIONS FOR THE WORK OF THIS DESIGN RELEASE.

### Specifications

1. Table of Contents for Project Manual Volume 2: REPLACE this section in its entirety.
2. Section 01 2100 - ALLOWANCES: REPLACE this section in its entirety.

ADD Paragraph 3.3.A -

2. Allowance No. 2; Quantity Allowance: Include one hundred (100) 12-inch by 12-inch Paver #1 with up to four (4) lines of text, sixteen (16) characters per each line.
  - a. Coordinate quantity allowance adjustment with unit-price requirements in Division 1 Section "Unit Prices."
3. Allowance No. 3; Quantity Allowance: Include one hundred (100) 24-inch by 24-inch Paver #1 with up to six (6) lines of text, thirty (30) characters per each line or a pre-selected logo and up to four (4) lines of text, thirty (30) characters per each line.
  - b. Coordinate quantity allowance adjustment with unit-price requirements in Division 1 Section "Unit Prices."
3. Section 01 2200 - UNIT PRICES: REPLACE this section in its entirety.

ADD Paragraph 3.1.A.20.b:

- b. Refer to Section 01 2100 - ALLOWANCES, Schedule of Allowances, Allowance No. 2 for base bid material allowances.

ADD Paragraph 3.1.A.21.b:

- b. Refer to Section 01 2100 - ALLOWANCES, Schedule of Allowances, Allowance No. 3 for base bid material allowances.

**MACKEY COMPLEX RENOVATION AND ADDITION – DESIGN RELEASE 6**  
**ROSS-ADE FOUNDATION - WEST LAFAYETTE, INDIANA**

---

4. Section 32 1313 - CONCRETE PAVING

ADD: Paragraph 1.7

1.7 DEFINITIONS

- A. Sand Release Finish: Sandblast look finish accomplished using a TOPCOAT surface retarder.

DELETE: Paragraph 2.3.D:

- D. Tactile Warning Concrete Pavers: Whitacre Greer, 1400 S. Mahoning Avenue, Alliance, Ohio 800-947-2837. Brick Pavers with truncated domes, color Dark Antique, to be utilized at all pedestrian ways required to meet ADAAG standards.

ADD: Paragraph 3.6.F.1 add at end of paragraph:

"All sawn joints to fully extend to building and vertical faces."

AMEND: All references to "Sand matrix finish" should read "Sand release finish."

5. Section 32 1317 - RUSTIC TERRAZZO PAVEMENT; INSERT new section in its entirety.

6. Section 32 1413 - CONCRETE UNIT PAVERS

AMEND: Paragraph 2.2 to read:

2.2 PAVER 1 – CONCRETE UNIT PAVERS, ENGRAVED

- A. Manufacturer: Wausau Tile, Wausau WI (800) 388-8728
1. Product: Cotillion III
  2. Sizes 24" x 24" x 2 3/4" and 12" x 12" x 2 3/4"
  3. Paver Color: FDX-5008
  4. Engraving font: Minion Pro
  5. Epoxy letter filler color: Black
  6. Joint Filler: Sand, 100% passing through #16 sieve (ASTM D994)
  7. Owner to provide names and graphics to manufacturer

Drawings (Revised)

General:

7. AMEND: All references to Detail E5/L501 Tree Pit should reference Detail M5/L501 Tree Pit w/ Grate.
8. ADD: The existing Paving Mockup on site is NOT to be used as a control sample. In-place mock-ups for each type of paving material are required per the specifications and will be reviewed for use of correct materials, craftsmanship, and quality of finish. Contractor shall not proceed with paving until approval of in-place mock-up is received. The personnel installing in-place mockup shall be the personnel installing that specific finished paving material for the entire project.

**MACKEY COMPLEX RENOVATION AND ADDITION – DESIGN RELEASE 6**  
**ROSS-ADE FOUNDATION - WEST LAFAYETTE, INDIANA**

---

9. UTILITY CLEANOUT IN PLANTING AREAS: Refer to C series drawings for locations.

Attachments

**PROJECT MANUAL, VOLUME 1**  
NON-APPLICABLE

**PROJECT MANUAL, VOLUME 2 (revised)**  
SECTION 00 0002 – TABLE OF CONTENTS  
SECTION 01 2100 – ALLOWANCES  
SECTION 01 2200 – UNIT PRICES  
SECTION 32 1317 - RUSTIC TERRAZZO PAVEMENTS

**Drawings**  
LSK-6-001

**NOTE: Bidders must acknowledge receipt of this Addendum by listing the number and date, where provided, on the Bid Form (document provided by Owner).**

**MACKEY COMPLEX RENOVATION AND ADDITION – DESIGN RELEASE 6**

**ROSS-ADE FOUNDATION - WEST LAFAYETTE, INDIANA**

**PROJECT MANUAL  
VOLUME 2**

Division	Section Title	Revision Date
----------	---------------	---------------

**PROCUREMENT AND CONTRACTING DOCUMENTS GROUP**

**DIVISION 00 - PROCUREMENT AND CONTRACTING REQUIREMENTS**

00 0001	SPECIFICATION CERTIFICATION PAGES	04/15/10
<b>00 0002</b>	<b>TABLE OF CONTENTS</b>	<b>04/26/10</b>

REMAINING SECTIONS - SEE VOLUME 1

**SPECIFICATIONS GROUP**

*General Requirements Subgroup*

**DIVISION 01 - GENERAL REQUIREMENTS**

01 1000	SUMMARY	04/15/10
<b>01 2100</b>	<b>ALLOWANCES</b>	<b>04/26/10</b>
<b>01 2200</b>	<b>UNIT PRICES</b>	<b>04/26/10</b>
01 2500	SUBSTITUTION PROCEDURES	04/15/10
01 2600	CONTRACT MODIFICATION PROCEDURES	04/15/10
01 2900	PAYMENT PROCEDURES	04/15/10
01 3100	PROJECT MANAGEMENT AND COORDINATION	04/15/10
01 3233	PHOTOGRAPHIC DOCUMENTATION	04/15/10
01 3300	SUBMITTAL PROCEDURES	04/15/10
01 4000	QUALITY REQUIREMENTS	04/15/10
01 4200	REFERENCES	04/15/10
01 5000	TEMPORARY FACILITIES AND CONTROLS	04/15/10
01 6000	PRODUCT REQUIREMENTS	04/15/10
01 7300	EXECUTION	04/15/10
01 7329	CUTTING AND PATCHING	04/15/10
01 7419	CONSTRUCTION WASTE MANAGEMENT AND DISPOSAL	04/15/10
01 7700	CLOSEOUT PROCEDURES	04/15/10
01 7823	OPERATION AND MAINTENANCE DATA	04/15/10
01 7839	PROJECT RECORD DOCUMENTS	04/15/10

*Facility Construction Subgroup*

**DIVISION 02 - EXISTING CONDITIONS**

02 4113	SELECTIVE SITE DEMOLITION	04/15/10
---------	---------------------------	----------

**DIVISION 03 - CONCRETE**

03 1000	CONCRETE FORMWORK AND SHORING	04/15/10
03 3000	CAST-IN-PLACE CONCRETE	04/15/10
03 2000	CONCRETE REINFORCEMENT	04/15/10

**DIVISION 04 - MASONRY**

04 4300	STONE MASONRY	04/15/10
---------	---------------	----------

**DIVISION 05 - METALS**

05 5213	PIPE AND TUBE RAILINGS	04/15/10
---------	------------------------	----------

**CONSTRUCTION DOCUMENTS**

HNTB Project No. 41962  
04/26/10 - ADDENDUM 1

**TABLE OF CONTENTS**

00 0002-1  
©2010 HNTB Corporation

# MACKEY COMPLEX RENOVATION AND ADDITION – DESIGN RELEASE 6

## ROSS-ADE FOUNDATION - WEST LAFAYETTE, INDIANA

Division	Section Title	Revision Date
----------	---------------	---------------

### DIVISION 07 - THERMAL AND MOISTURE PROTECTION

07 9213 SITE JOINT SEALANTS 04/15/10

### DIVISION 12 - FURNISHINGS

12 9300 SITE FURNISHINGS AND AMENITIES 04/15/10

### *Site and Infrastructure Subgroup*

### DIVISION 31 - EARTHWORK

31 1000 SITE CLEARING 04/15/10

31 2000 EARTH MOVING 04/15/10

31 2319 DEWATERING 04/15/10

31 3219 GEOTEXTILE 04/15/10

### DIVISION 32 - EXTERIOR IMPROVEMENTS

32 124 PERVIOUS CONCRETE PAVING 04/15/10

**32 1313 CONCRETE PAVING 04/26/10**

**32 1317 RUSTIC TERRAZZO PAVEMENT(New Section Addendum 1) 04/26/10**

32 1373 PAVEMENT JOINT SEALANTS 04/15/10

**32 1413 CONCRETE UNIT PAVERS 04/26/10**

32 9113 TOPSOIL PREPARATION 04/15/10

### DIVISION 33 - UTILITIES

33 0401 INSTALLATION OF UNDERGROUND PIPING 04/15/10

33 0500 COMMON WORK RESULTS FOR UTILITIES 04/15/10

33 4100 STORM UTILITY DRAINAGE PIPING 04/15/10

33 4600 SUBDRAINAGE 04/15/10

### Appendices for Design Release 6

#### APPENDIX A.6

CODE REPORT SUMMARY 03/30/09

#### APPENDIX B.6

FINAL GEOTECHNICAL ENGINEERING STUDY REPORT WITH ADDENDUM 08/12/08

#### APPENDIX C.6

STORMWATER ANALYSIS 04/15/10

#### APPENDIX D.6

BMP OPERATIONS AND MAINTENANCE MANUAL 04/15/10

#### APPENDIX E.6

STORM WATER POLLUTION PREVENTION PLAN (SWPPP) 03/17/09

### END OF TABLE OF CONTENTS

### SPECIFICATION BID ISSUE KEY:

**Issue Date: Issue Title:**

04/15/10: CONSTRUCTION DOCUMENTS (Original issue)

**04/26/10: ADDENDUM 1**

**REVISIONS: BOLD and Underlined for sections revised or edited in this issue.**  
Strikethrough for sections deleted this issue

**CONSTRUCTION DOCUMENTS**

**HNTB Project No. 41962**

**04/26/10 - ADDENDUM 1**

**TABLE OF CONTENTS**

**00 0002-2**

**©2010 HNTB Corporation**

**MACKEY COMPLEX RENOVATION AND ADDITION – DESIGN RELEASE 6**  
**ROSS-ADE FOUNDATION - WEST LAFAYETTE, INDIANA**

---

**SECTION 01 2100 - ALLOWANCES**

PART 1 - GENERAL

1.1 RELATED DOCUMENTS

- A. Drawings and general provisions of the Contract, including General and Supplementary Conditions and other Division 01 Specification Sections, apply to this Section.
  - 1. See General Conditions, Section 31, Allowances for terms and conditions.

1.2 SUMMARY

- A. Section includes administrative and procedural requirements governing allowances.
  - 1. Certain items are specified in the Contract Documents by allowances. Allowances have been established in lieu of additional requirements and to defer selection of actual materials and equipment to a later date when direction will be provided to the Contractor. If necessary, additional requirements will be issued by Change Order.
- B. Types of allowances include the following:
  - 1. Contingency allowances.
  - 2. Quantity allowances.
  - ~~2. Unit cost allowances.~~
- C. Related Sections:
  - 1. Division 01 Section "Unit Prices" for procedures for using unit prices.
  - 2. Division 01 Section "Quality Requirements" for procedures governing the use of allowances for testing and inspecting.
  - 3. Divisions 02 through 49 Sections for items of Work covered by allowances.

1.3 SELECTION AND PURCHASE

- A. At the earliest practical date after award of the Contract, advise Architect of the date when final selection and purchase of each product or system described by an allowance must be completed to avoid delaying the Work.
- B. At Architect's request, obtain proposals for each allowance for use in making final selections. Include recommendations that are relevant to performing the Work.

1.4 SUBMITTALS

- A. Submit proposals for purchase of products or systems included in allowances, in the form specified for Change Orders.
- B. Submit invoices or delivery slips to show actual quantities of materials delivered to the site for use in fulfillment of each allowance.

## **MACKEY COMPLEX RENOVATION AND ADDITION – DESIGN RELEASE 6**

### **ROSS-ADE FOUNDATION - WEST LAFAYETTE, INDIANA**

- C. Submit time sheets and other documentation to show labor time and cost for installation of allowance items that include installation as part of the allowance.
- D. Coordinate and process submittals for allowance items in same manner as for other portions of the Work.

#### 1.5 COORDINATION

- A. Coordinate allowance items with other portions of the Work. Furnish templates as required to coordinate installation.

#### 1.6 CONTINGENCY ALLOWANCES

- A. Use the contingency allowance only as directed by Construction Manager or Purdue Superintendent for Owner's purposes and only by Change Orders that indicate amounts to be charged to the allowance.
- B. Contractor's overhead, profit, and related costs for products and equipment ordered by Owner under the contingency allowance are included in the allowance and are not part of the Contract Sum. These costs include delivery, installation, taxes, insurance, equipment rental, and similar costs.
- C. At Project closeout, credit unused amounts remaining in the contingency allowance to Owner by Change Order.

#### 1.7 QUANTITY ALLOWANCES

- A. Allowance shall include cost to Contractor of specific products and materials ordered by Owner or selected by Architect under allowance and shall include freight and delivery to Project site.
- B. Unless otherwise indicated, Contractor's costs for receiving and handling at Project site, labor, installation, overhead and profit, and similar costs related to products and materials under allowance shall be included as part of the Contract Sum and not part of the allowance.

#### 4.71.8 ADJUSTMENT OF ALLOWANCES

- A. Allowance Adjustment: To adjust allowance amounts, prepare a Change Order proposal based on the difference between purchase amount and the allowance, multiplied by final measurement of work-in-place where applicable. If applicable, include reasonable allowances for cutting losses, tolerances, mixing wastes, normal product imperfections, and similar margins.
  - 1. Include installation costs in purchase amount only where indicated as part of the allowance.
  - 2. If requested, prepare explanation and documentation to substantiate distribution of overhead costs and other margins claimed.
- B. Submit claims for increased costs because of a change in scope or nature of the allowance described in the Contract Documents, whether for the purchase order amount or Contractor's handling, labor, installation, overhead, and profit.

**MACKEY COMPLEX RENOVATION AND ADDITION – DESIGN RELEASE 6**  
**ROSS-ADE FOUNDATION - WEST LAFAYETTE, INDIANA**

---

1. Do not include Contractor's or subcontractor's indirect expense in the Change Order cost amount unless it is clearly shown that the nature or extent of work has changed from what could have been foreseen from information in the Contract Documents.
2. No change to Contractor's indirect expense is permitted for selection of higher- or lower-priced materials or systems of the same scope and nature as originally indicated.

PART 2 - PRODUCTS (Not Used)

PART 3 - EXECUTION

3.1 EXAMINATION

- A. Examine products covered by an allowance promptly on delivery for damage or defects. Return damaged or defective products to manufacturer for replacement.

3.2 PREPARATION

- A. Coordinate materials and their installation for each allowance with related materials and installations to ensure that each allowance item is completely integrated and interfaced with related work.

3.3 SCHEDULE OF ALLOWANCES

A. **06-01D: Hardscape Allowances:**

1. Allowance No. 1; Contingency Allowance: Include a contingency allowance of \$50,000 for Additional Demolition and Restoration requirements.
2. Allowance No. 2; Quantity Allowance: Include one hundred (100) 12-inch by 12-inch Paver #1 with up to four (4) lines of text, sixteen (16) characters per each line.
  - a. Coordinate quantity allowance adjustment with unit-price requirements in Division 01 Section "Unit Prices."
3. Allowance No. 3; Quantity Allowance: Include one hundred (100) 24-inch by 24-inch Paver #1 with up to six (6) lines of text, thirty (30) characters per each line or a pre-selected logo and up to four (4) lines of text, thirty (30) characters per each line.
  - a. Coordinate quantity allowance adjustment with unit-price requirements in Division 01 Section "Unit Prices."

**END OF SECTION 01 2100**

---

**MACKEY COMPLEX RENOVATION AND ADDITION – DESIGN RELEASE 6**  
**ROSS-ADE FOUNDATION - WEST LAFAYETTE, INDIANA**

---

**SECTION 01 2200 - UNIT PRICES**

**PART 1 - GENERAL**

**1.1 RELATED DOCUMENTS**

- A. Drawings and general provisions of the Contract, including General and Supplementary Conditions and other Division 01 Specification Sections, apply to this Section.

**1.2 SUMMARY**

- A. Section includes administrative and procedural requirements for unit prices.
- B. Related Sections:
  - 1. Division 01 Section "Contract Modification Procedures" for procedures for submitting and handling Change Orders.
  - 2. Division 01 Section "Quality Requirements" for general testing and inspecting requirements.

**1.3 DEFINITIONS**

- A. Unit price is an amount incorporated in the Agreement, applicable during the duration of the Work as a price per unit of measurement for materials, equipment, or services, or a portion of the Work, added to or deducted from the Contract Sum by appropriate modification, if the scope of Work or estimated quantities of Work required by the Contract Documents are increased or decreased.

**1.4 PROCEDURES**

- A. Unit prices include all necessary material, plus cost for delivery, installation, insurance, applicable taxes, overhead, and profit.
- B. Measurement and Payment: Refer to individual Specification Sections for work that requires establishment of unit prices. Methods of measurement and payment for unit prices are specified in those Sections.
- C. Owner reserves the right to reject Contractor's measurement of work-in-place that involves use of established unit prices and to have this work measured, at Owner's expense, by an independent surveyor acceptable to Contractor.
- D. List of Unit Prices: A schedule of unit prices is included in Part 3. Specification Sections referenced in the schedule contain requirements for materials described under each unit price.

---

**MACKEY COMPLEX RENOVATION AND ADDITION – DESIGN RELEASE 6**  
**ROSS-ADE FOUNDATION - WEST LAFAYETTE, INDIANA**

---

PART 2 - PRODUCTS (Not Used)

PART 3 - EXECUTION

3.1 SCHEDULE OF UNIT PRICES

A. **Unit Prices: General Trades, Hardscape, Bid Package 06-01D – 2010**

1. Unit Price No. 1: Asphalt Removal.
  - a. Unit of Measurement: Square yard of asphalt removed.
2. Unit Price No. 2: Concrete Removal.
  - a. Unit of Measurement: Square yard of concrete removed.
3. Unit Price No. 3: Curb Removal.
  - a. Unit of Measurement: Linear feet of curb removed.
4. Unit Price No. 4: Asphalt Patching.
  - a. Unit of Measurement: Ton of asphalt placed.
5. Unit Price No. 5: Concrete Curb Replacement.
  - a. Unit of Measurement: Linear foot of concrete curb placed.
6. Unit Price No. 6: Excavate and haul soils offsite.
  - a. Unit of Measurement: Cubic yard of soil removed.
7. Unit Price No. 7: Import and Place Granular Fill.
  - a. Unit of Measurement: Cubic yard of fill placed.
8. Unit Price No. 8: Excavate and Haul Off Site Foundations/Debris.
  - a. Unit of Measurement: Cubic yard of removed.
9. Unit Price No. 9: 6' Chain-link fencing.
  - a. Unit of Measurement: Linear Feet installed.
10. Unit Price No. 10: 40 CY Dumpster.
  - a. Unit of Measurement: Cost per pull.
11. Unit Price No. 11: 20 CY Dumpster.
  - a. Unit of Measurement: Cost per pull.
12. Unit Price No. 12: Paving - Integral colored concrete w/ sand release finish (refer to plans and specifications for additional information.)
  - a. Unit of Measurement: Square feet of concrete placed.

## **MACKEY COMPLEX RENOVATION AND ADDITION – DESIGN RELEASE 6**

### **ROSS-ADE FOUNDATION - WEST LAFAYETTE, INDIANA**

13. Unit Price No. 13: Paving - Standard concrete w/ medium broom finish (refer to plans and specifications for additional information.)
  - a. Unit of Measurement: Square feet of concrete placed.
14. Unit Price No. 14: Paving - Standard concrete w/ sand release finish (refer to plans and specifications for additional information.)
  - a. Unit of Measurement: Square feet of concrete placed.
15. Unit Price No. 15: Paver #1 (refer to plans and specifications for additional information.)
  - a. Unit of Measurement: Square feet of paver placed.
16. Unit Price No. 16: Paver #2 (refer to plans and specifications for additional information.)
  - a. Unit of Measurement: Square feet of paver placed.
17. Unit Price No. 17: Heavy-duty Asphalt (refer to plans and specifications for additional information.)
  - a. Unit of Measurement: Square feet of asphalt placed.
18. Unit Price No. 18: Banded Pavement - Granolithic Terrazzo.
  - a. Unit of Measurement: Square feet of terrazzo placed.
19. Unit Price No. 19: Banded Pavement - Recycled Glass Concrete Paver.
  - a. Unit of Measurement: Square feet of paver placed.
20. Unit Price No. 20: Premium to add text to 12" by 12" brick paver.
  - a. Unit of Measurement: Cost paver.
  - b. Refer to Section 01 2100 - ALLOWANCES, Schedule of Allowances, Allowance No. 2 for base bid material allowances.
21. Unit Price No. 21: Premium to add logo and text to 24" by 24" brick paver.
  - a. Unit of Measurement: Cost per paver.
  - b. Refer to Section 01 2100 - ALLOWANCES, Schedule of Allowances, Allowance No. 3 for base bid material allowances.
22. Unit Price No. 22: Concrete Light Pole Base Foundation, (per drawing A1/L502)
  - a. Unit of Measurement: Cost per foundation.

**END OF SECTION 01 2200**

---

**MACKEY ARENA RENOVATION & EXPANSION – BID PACKAGE NO. 6**  
**ROSS-ADE FOUNDATION - WEST LAFAYETTE, INDIANA**

---

**SECTION 32 1317 – RUSTIC TERRAZZO PAVING**

**PART 1 - GENERAL**

**1.1 RELATED DOCUMENTS**

- A. Drawings and general provisions of the Contract, including General and Supplementary Conditions and Division 1 Specification Sections, apply to this Section.

**1.2 SUMMARY**

- A. This Section includes the following:
- B. Related Sections include the following:
  - 1. Division 03 Section “Cast-in-Place Concrete” for concrete mix requirements
  - 2. Division 07 Section “Pavement Joint Sealants” for jointing requirements
  - 3. Division 32 Section “Concrete Paving” for concrete materials, joints and related items

**1.3 SUBMITTALS**

- A. General: Submit the following according to Conditions of Contract and Division 1 Specification Sections.
- B. Product Data: Manufacturer’s technical information and installation instructions for rustic terrazzo, accessory items, and materials.
- C. Product Certification: Verify suppliers/manufacturer’s written certification that terrazzo materials meet or exceed specified NTMA properties.
- D. Installer Certification: Verify qualifications of installer including years of experience (minimum of three (3) years required), three (3) client references, and five (5) project locations.
- E. Samples: 12” square samples submitted for each pattern and color of granolithic pavement.
- F. Mock-Up:
  - 1. Prior to installation of paving: Fabricate mock-ups using materials, patterns, and joint treatments indicated for project work including special features for expansion joints and contiguous work.
  - 2. Build Mockups according to drawings provided by Landscape Architect
  - 3. Obtain Landscape Architect’s acceptance of mock-up prior to starting paver work.
  - 4. All costs incidental to the construction of the mock up shall be borne by the contractor. Unsatisfactory mock ups will be replaced to the Owner’s satisfaction.
  - 5. Retain Mockup during construction as a standard for evaluating completed paver work. Do not move or destroy mock up until paver work is complete.
- G. Maintenance Instruction: Submit two copies of written instructions of recommended periodic maintenance of rustic terrazzo.

---

## MACKEY ARENA RENOVATION & EXPANSION – BID PACKAGE NO. 6

### ROSS-ADE FOUNDATION - WEST LAFAYETTE, INDIANA

---

#### 1.4 Quality Assurance

1. NTMA Standards: Comply with specified provision and recommendations of National Terrazzo and Mosaic Association, Inc. (NTMA)
2. Qualifications of Installers: Use only experienced installers and finishers with successful experience in exterior paving of size and extent.
  - a. Installer must be a member of the National Terrazzo and Mosaic Association
  - b. Installer must have a minimum of 5 years of experience and must supply four (4) successful pervious concrete pavement projects within the last three (3) years, including, but not limited to, Project name and address, owner name and current contact information
  - c. Pre-qualified suppliers/installers:
    - 1) Santarossa Mosaic and Tile Company, 317.632.9494
    - 2) The ART Mosaic and Tile Company, 574.287.8131

#### PART 2 - PRODUCTS

#### 2.1 CEMENTITIOUS TERRAZZO MATERIALS

- A. Portland Cement: ASTM C150, Color: standard Grey Cement and or gray and white cement mix where required, except as modified to comply with NTMA requirements for compressive strength. Obtain cement from single source for each required color.
- B. Sand: ASTM C33
- C. Water: Clean, free of on soluble salts or other deleterious substances
- D. Aggregate:
  1. Natural, sound, crushed granite and marble chips without excessive flats or flakes, complying with NTMA standards
  2. Colors and gradation of aggregate: Size #A, #1, and # 0 as per paving mix design.
  3. Silica sand 5% and 10% coarse, clean, washed, locally available sand.
- E. Nylon Fiber Reinforcement: Non-collated virgin nylon monofilament fibers or collated fibrillated polypropylene fibers. Subject to compliance with requirements, provide one of the following plastic fiber reinforcements:
  1. Nycon, Inc. "Nycon"
  2. Fibermesh, Inc. "Fibermesh"
  3. Forta Corp. "Forta CR"
  4. Fiber-Ad Corporation "Fiber-Ad"
- F. Air Entraining Admixture: ASTM C260, certified by manufacturer to be compatible with other required admixtures
  1. Euclid Chemical Co. "Air-Mir"
  2. Sika Corp "Sika Aer"
  3. Master Builders "MB-VR" or "MB-AE"
  4. W. R. Grace "Darex AEA" or "Daravair" or "Airlon AEA"
- G. Wood Stops: Use temporarily to create control joints as indicated in the drawings.

**MACKEY ARENA RENOVATION & EXPANSION – BID PACKAGE NO. 6**  
**ROSS-ADE FOUNDATION - WEST LAFAYETTE, INDIANA**

---

- H. Joint Sealant: Type SL Elastomeric Polyurethane Sealant for Concrete
  - 1. Manufacturer: SL-2 Sonolastic; Sonneborn, or approved equal
  - 2. Backer material: Provide joint-sealant backer materials that are nonstaining; are compatible with joint substrates, sealants, primers, and other joint fillers; and are approved for applications indicated by joint sealant manufacturer based on field experience and laboratory testing.
    - a. ASTM D 5249; Type 2; of thickness and width required to control sealant depths, prevent bottom-side adhesion of sealant, and fill remainder of joint opening under sealant.
- I. Control Joint Filler: Polymeric Joint Sand (Super Sand), color to match banding cement.
  - 1. Shall be applied only when pavement is dry
  - 2. Joints to be 5/8" wide
- J. Sealer:
  - 1. Shall not discolor or amber.
  - 2. Penetrating, solvent acrylic-type specifically prepared for use with rustic terrazzo.
  - 3. Rustic Terrazzo to be cleaned and sealed a second time within 30 days of the one-year warrantee walk-through

2.2 TERRAZZO MIX DESIGN

- A. Proportions
  - 1. Concrete substrate: Refer to Division 32 Section "Concrete Paving" for general concrete mix, reinforcement, curing, and related details.
  - 2. Terrazzo Topping:
    - a. One bag (94 lb) of Poland cement per 200 lbs of aggregate and 4 ½ to 5 gallons of clean water.
    - b. Depth of topping: 3/4" minimum. Clean white sand may be added to mix.
    - c. Mixing: Add aggregate, water, air entraining agent and Portland cement in proper proportions and mix thoroughly to uniform consistency. Maintain consistency by using same amount of water for all batches.
    - d. Composition for 16" bands
      - 1) Grey Cement – 100%, Air Entrainment 6%
      - 2) 1 lb black color per bag
      - 3) Raven Black Granite #1 - 50%
      - 4) Raven Black Granite #0 – 20%
    - e. Composition for 24" bands
      - 1) White Cement – 100%, Air Entrainment 6%
      - 2) 2 lbs light buff color per bag
      - 3) Rainbow Quartz #1— 40%
      - 4) Cibola Gold #1—30%
      - 5) Dark Baldwin Red #0 – 10%
      - 6) Amber Terrazzo glass #1—10%
      - 7) Silica Sand – 10%
  - 3. Chip density to be a minimum of 75%.

---

**MACKEY ARENA RENOVATION & EXPANSION – BID PACKAGE NO. 6**

---

**ROSS-ADE FOUNDATION - WEST LAFAYETTE, INDIANA****PART 3 - EXECUTION****3.1 PREPARATION**

- A. Clean and prepare concrete substrate to comply with NTMA specifications for type of terrazzo application indicated. Clean substrate of loose chips and foreign matter. Grind concrete substrate to provide surfaces within tolerances required by NTMA for type of terrazzo application.
- B. Start work only when all defects have been corrected by others.

**3.2 INSTALLATION, GENERAL**

- A. For cementitious terrazzo, comply with NTMA recommendations for proportioning mixes, installation of joints and for placing, curing, grinding, grouting, and finishing.
- B. Concrete underbed:
  - 1. Set control material around all control joint lines and other architectural features indicated on the drawings, full depth of concrete substrate slab.
  - 2. Soak concrete substrate slab thoroughly with clean water. Remove puddles.
  - 3. Place concrete underbed and screed to an elevation of  $\frac{3}{4}$ " below finished grade elevation, to accommodate  $\frac{3}{4}$ " granolithic topping.
  - 4. Install control joints before concrete hardens
  - 5. Expansion joint in base slab **MUST** align with joint locations in granolithic paving
- C. Rustic Granolithic Terrazzo Topping:
  - 1. Place rustic terrazzo
  - 2. Roll and compact topping with rollers to extract excess cement
  - 3. Expose aggregate by hosing; absorbent rolling
- D. Curing: Flood with clean water, or cover with 4 mil polyethylene sheeting.
- E. Provide control joints where indicated to a depth of 1/4 to 1/3 slab thickness
- F. Cleaning: When topping is sufficiently cured, apply a 1 to 10 solution of muriatic acid in water, scrub with a stiff broom and remove all latence, and rinse immediately with clean water to remove all traces of the acid. NOTE: Acid wash no sooner than 7 days after installation.
- G. Sealing:
  - 1. Rinse with clean water and allow to dry
  - 2. When thoroughly dry, apply the sealer in accordance with manufacturer's recommendations for use on rustic terrazzo.
- H. Caulking: Place sealant in joints as indicated on drawings and between changes in granolithic color not otherwise separated by expansion joints
- I. Protection
  - 1. Upon completion, the work shall be ready for final inspection and acceptance by the Owner or his agent
  - 2. General Contractor shall protect the finish pavement throughout construction.

**MACKEY ARENA RENOVATION & EXPANSION – BID PACKAGE NO. 6**

---

**ROSS-ADE FOUNDATION - WEST LAFAYETTE, INDIANA**

3. COMMUNICATE CLEARLY TO OWNER AND/OR OWNER'S REPRESENTATIVE THAT DE-ICING CHEMICALS AND OR SALT CAN DAMAGE RUSTIC TERRAZZO SURFACES. PROVIDE INFORMATION ABOUT ALTERNATIVE MEANS OF REMOVING ICE AND/OR SNOW SAFELY.

**END OF SECTION 31 1317**

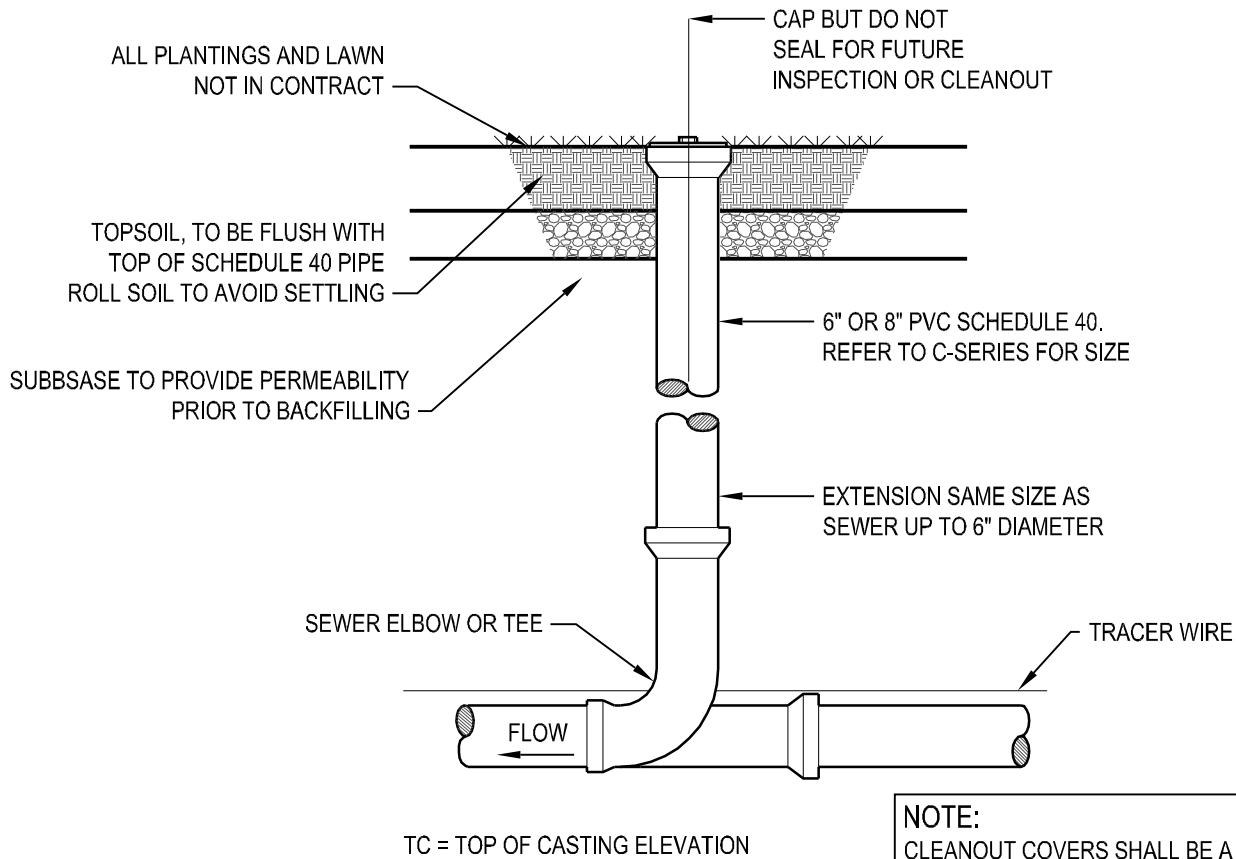

**NOTE:**  
 CLEANOUT COVERS SHALL BE A  
 THREADED-TYPE, WATER-TIGHT, AND  
 CAPPED AT ALL TIMES PER SECTION 201.08.



12 S. Main Street, Suite 100 Fortville, IN 46040  
 tel 317.485.6900 fax 317.485.6912  
 www.context-design.com



**HNTB Corporation**  
 The HNTB Companies  
 ARCHITECTS  
 ENGINEERS  
 PLANNERS

715 Kirk Drive  
 Kansas City, Missouri 64105  
 (816) 472-1201 Fax (816) 472-4060

ROSS-ADE FOUNDATION  
 MACKEY COMPLEX RENOVATION & ADDITION

UTILITY CLEANOUT IN PLANTING AREAS

SCALE: NTS

DESIGN RELEASE 6

HNTB NO.: 41962

DATE: 04/26/10

ISSUE: ADDENDUM 1

DWG:

DRAWING NO: **LSK-6-001**