

ADDENDUM NUMBER TWO

To the Drawings and Project Manual

Dated: 4 December 2008

Entitled:

PURDUE UNIVERSITY
Harrison Hall Sprinkler System and AC Renovation
West Lafayette, Indiana

Prepared By:

BSA LIFESTRUCTURES
9365 Counselors Row
Indianapolis, IN 46240

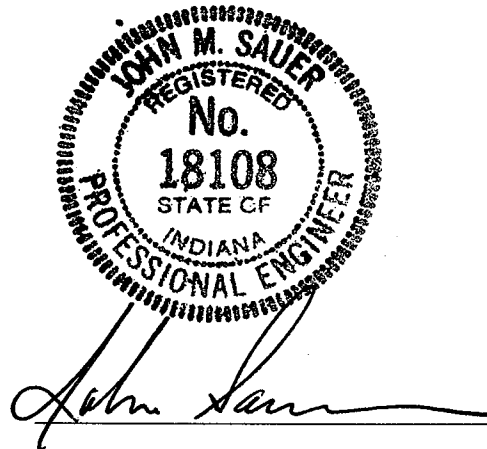

John M. Sauer
Indiana Registration No. 18108

Addendum Dated: 5 January 2009

Project Number: 359040

CHANGES TO THE PROJECT MANUAL

1. **SECTION 08 7100 - DOOR HARDWARE:**
 - a. 2.13, B .1 “Basis of Design”: Replace “Hager MB1964” with “Hager M-511, 26D, Left and Right handed”

2. **SECTION 09 9123 - INTERIOR PAINTING:**
 - a. Add to 1.4 “Quality Assurance
 - B. Adhesion Tests
 - .1 Provide test reports by qualified independent laboratories indicating all paint systems are in full compliance with ASTM D3359.”

 - b. Add to 3.5:
 - “D. Plaster Substrate
 1. High Performance Architectural Latex System: MPI #140
 - a. Prime Coat: Interior acrylic latex primer.
 - b. Intermediate Coat: High performance architectural latex.
 - c. Top Coat: High performance architectural latex.”

CHANGES TO THE DRAWINGS

1. **DRAWING A601:**
 - a. Detail 1, Typical Student Room Finish Plan: Refer to attached Drawing R020.

 - b. Detail 2, Alternate #3: Typical Student Room Finish Plan: Refer to attached Drawing R021.

 - c. General Finish Notes: Refer to attached Drawing R022.

END OF ADDENDUM NUMBER TWO

ATTACHMENTS: Revision Drawings R020, R021, R022

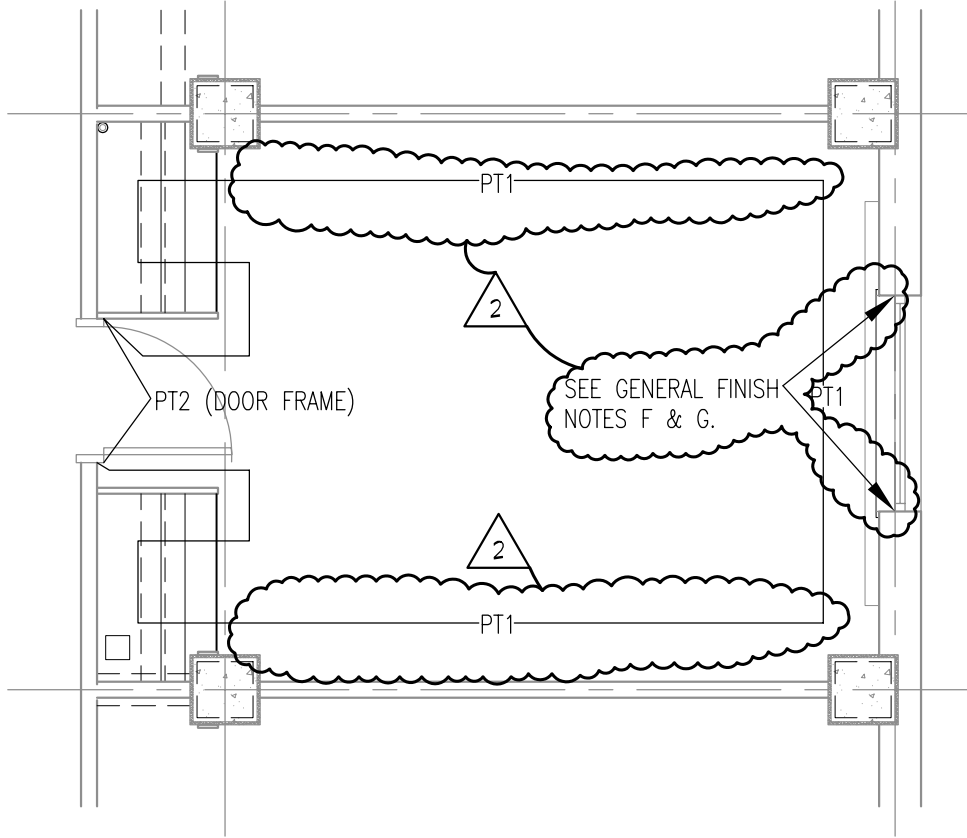

1 **TYPICAL STUDENT ROOM FINISH PLAN** $\frac{1}{4}'' = 1'-0''$

BSA
Life Structures

9365 Counselors Row
Indianapolis, IN 46240-1478

ph 317.819.7878 fx 317.819.7288
www.bsalifestructures.com



synthesis

SYNTHESIS INCORPORATED
251 N ILLINOIS STREET
SUITE 200
INDIANAPOLIS, IN 46204

PH: 317.951.9500
FAX: 317.951.9501
www.synthinc.com

CLIENT NO.

9354

DATE

05 JAN 2009

REFERENCE SHEET

A601

**PURDUE
UNIVERSITY**

HARRISON HALL – 2009
WEST LAFAYETTE, INDIANA

COMMISSION

359040

RO20

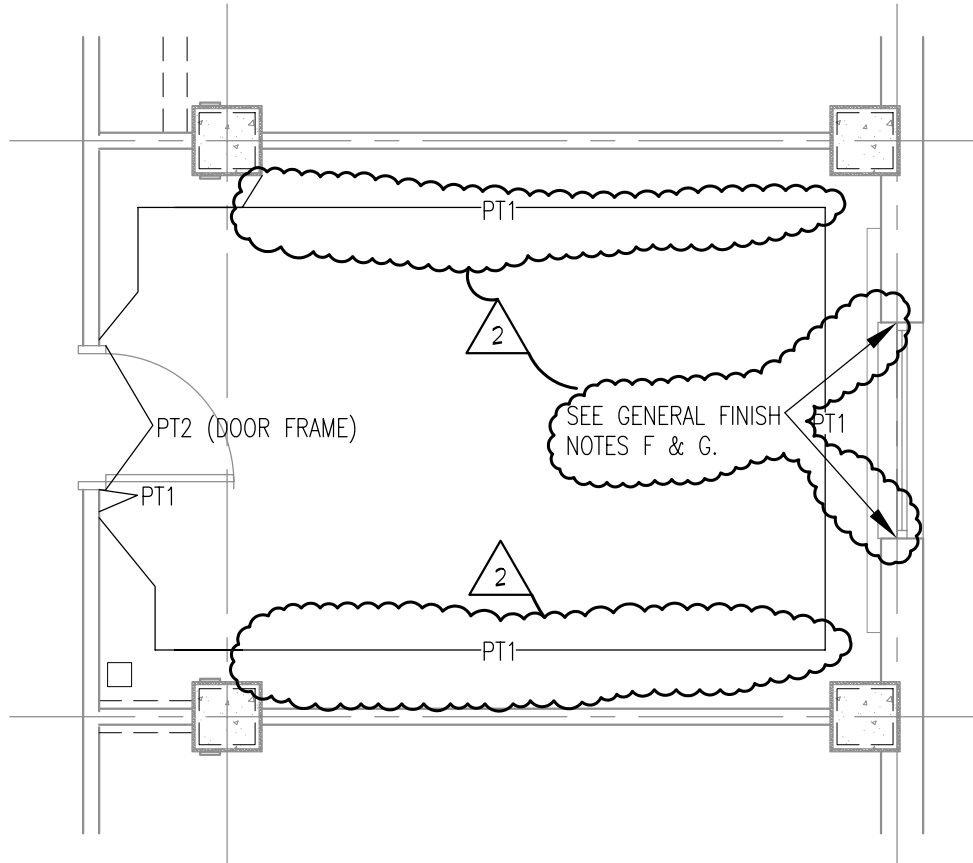

ALTERNATE #3
TYPICAL STUDENT ROOM FINISH PLAN

2

1/4" = 1'-0"



BSA
Life Structures

9365 Counselors Row
 Indianapolis, IN 46240-1478

ph 317.819.7878 fx 317.819.7288
 www.bsalifestructures.com



synthesis

SYNTHESIS INCORPORATED
 251 N ILLINOIS STREET
 SUITE 200
 INDIANAPOLIS, IN 46204
 PH: 317.951.9500
 FAX: 317.951.9501
 www.synthinc.com

CLIENT NO.

DATE

9354

05 JAN 2009

PURDUE
UNIVERSITY

HARRISON HALL – 2009
 WEST LAFAYETTE, INDIANA

COMMISSION

REFERENCE SHEET

359040

RO21

A601

GENERAL FINISH NOTES:

- A. PAINT METAL FACE OF ACCESS PANELS AND ELECTRICAL PANELS TO MATCH ADJACENT WALL PAINT. PANELS TO BE ELECTROSTATICALLY PAINTED OFF-SITE.
- B. REFER TO INTERIOR ELEVATIONS FOR ADDITIONAL FINISH INFORMATION.
- C. PAINT ALL SUITE DOOR FRAMES PT2.
- D. REPLACEMENT VINYL BASE IN RESIDENCE ROOMS TO MATCH EXISTING IN DIMENSION, COLOR AND MATERIAL.
- E. REPLACEMENT VCT IN RESIDENCE ROOMS TO MATCH EXISTING.
- F. ALTERNATE #1: PROVIDE SEALANT AT PERIMETER OF ALL NEW WINDOW SILLS
- G. PROVIDE SEALANT AT PERIMETER OF WINDOW.

2



9365 Counselors Row
Indianapolis, IN 46240-1478

ph 317.819.7878 fx 317.819.7288
www.bsalifestructures.com



SYNTHESIS INCORPORATED
251 N ILLINOIS STREET
SUITE 200
INDIANAPOLIS, IN 46204

PH: 317.951.9500
FAX: 317.951.9501
www.synthinc.com

CLIENT NO. 9354

DATE 05 JAN 2009

**PURDUE
UNIVERSITY**

HARRISON HALL – 2009
WEST LAFAYETTE, INDIANA
COMMISSION 359040

RO22
REFERENCE SHEET A601